

Dilas FT

FT1800



Digital communication: Profibus-DP, Profinet, Ethernet Modbus-TCP, EtherNet/IP



EtherNet/IP™

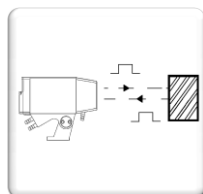

High temperature targets - Long range - High accuracy

Easy setup and installation

Design for steel industry conditions



Introduction

The **Dilas FT1800** is a digital, high resolution, non-contact laser distance measurement or detection sensor. The target may be hot or cold, stationary or moving. **Dilas FT1800** measures on all non-shiny surfaces.

The operation of the **Dilas FT1800** is based on time-of-flight measurement. The sensor calculates the distance of the target surface using the time of flight of visible laser light pulses.

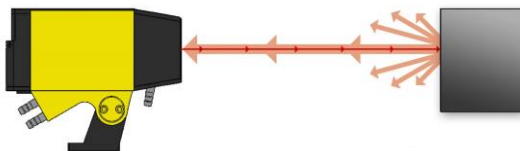

The measurement is delivered on an analogue output or on the digital communication.

Presentation

The **Dilas FT1800** is an autonomous sensor mounted in compact aluminium housing, IP66. The sensor can be ordered with mounting bracket or mounting stand and water-cooling jacket.

A digital display indicates the measured distance and two LED indicate status of sensor.

For the models with digital communication, two additional LED indicate the communication link status.

The sensor can work as a standalone unit: in that case, the setup is made from the control panel at the back of sensor.



Features and benefits

- Two internal laser modules: 1 mW or 5 mW, for a better measuring margin on very hot targets or in difficult conditions
- Target temperature: up to 1300 °C
- Analogue output : 4-20 mA
- Digital communication : Profibus-DP, Profinet, Modbus-TCP, EtherNet/IP
- Visible red laser beam
- Autonomous sensor: ready to use, no calibration required
- Integrated 5 digits display
- Easy sensor setup with pre-set distances selection
- Extended configuration of customized measuring range and response time
- Special modes ('Time') optimized for: Detection / Tracking / Averaging / Fixed Sampling
- Optional Water cooling & air purging – Optional Heat Shield & additional cooling plate.

Applications

The **Dilas FT1800** offers different modes optimized for different applications. The setup of the mode is very easy and quick via the back panel selector in the "Time" position. Be sure to select the mode adapted to your own situation:

- Auto mode gives measurement as soon as it is available with the best accuracy. The measuring time is not fixed and depends on the measurement conditions: reflectivity of the target, distance. If the measurement is not possible, the sensor delivers an error code after maximum 6 seconds.



- **Fixed sampling time** allows user to get a repeatable and fixed measuring time: the target needs to be always measurable within this fixed time to use this mode, otherwise some error code may appear.
- **Tracking mode**: when the target is moving in the axis of the sensor, this mode is recommended and provides better results and refreshment time.
- **Detection mode** is interesting for applications where product or background is not measurable within a fixed time. Instead of freezing the detection output and the measurement value like for other modes, the FT1800 in detection mode will release the output and measurement after the fixed time.
- **Average mode** makes a moving average (x2 or x4) of the last values, to get a more stabilized and accurate measurement.

Note: if a window glass is used in front of the **Dilas FT1800** (like in furnace application), it should be installed with an angle 5° to 10° to avoid reflections and possible errors or wrong measurements. The glass should have air purging protection and be clean.

Typical Applications

↪ Length measurement

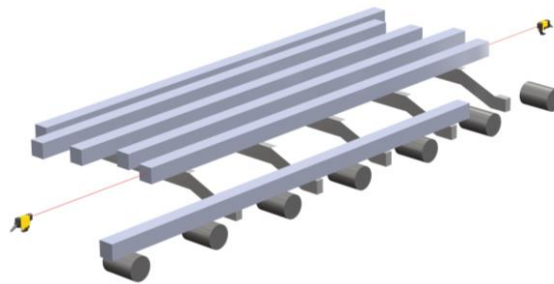

↪ Position measurement

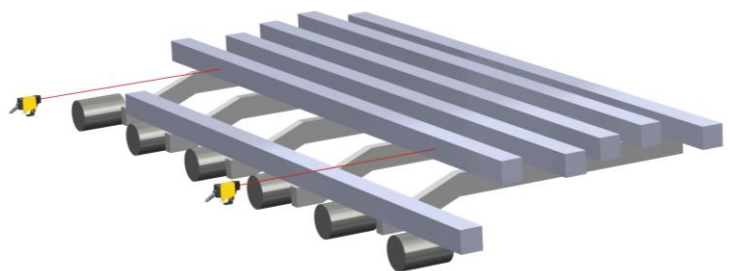

↪ Position measurement before furnace charging

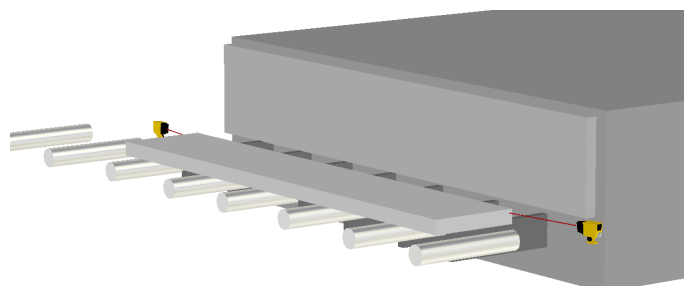



↪ Length & position measurement at furnace entry

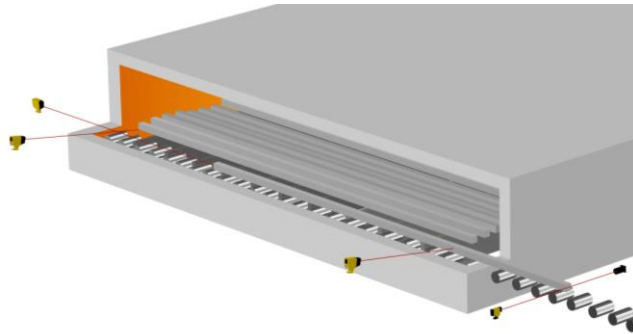

↪ Strip loop control in furnace

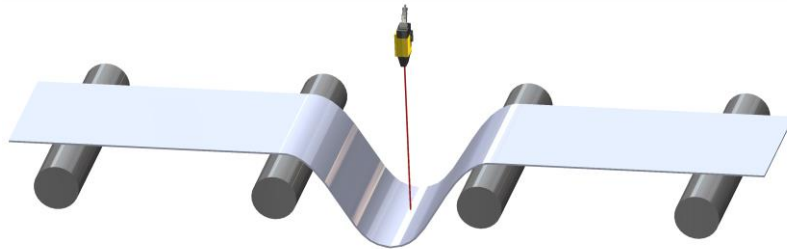

↪ Static slab dimensions measurement

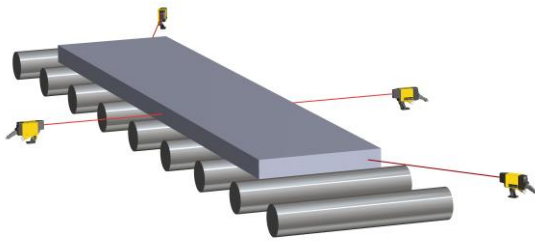

↪ Hot product position measurement



↪ Transportation cart position measurement

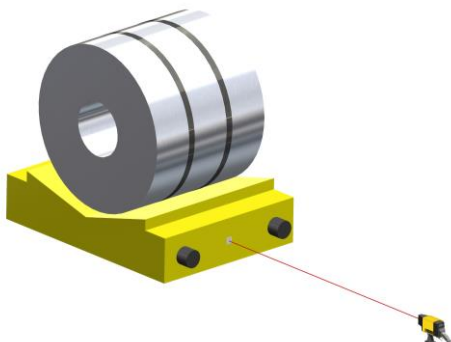

↪ Stop position control

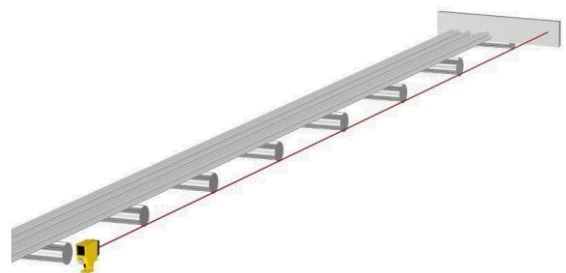



Technical specifications

Model	FT181•••	FT185•••
Laser (IEC 60825-1:2014)	≤1 mW class 2, 650 nm	≤ 5 mW class 3R, 650 nm
Beam divergence / Spot diameter	0.6 mrad / 6 mm at 10 m ; 30 mm at 50 m ; 60mm at 100 m	
Maximum target T°	1100 °C (2012 °F)	1300 °C (2370 °F)
Measurement Range vs Surface		
- Black surface (6% remission)	0.3 to 25 m	0.3 to 30 m
- Natural surface, grey (13% remission)	0.3 to 30 m	0.3 to 35 m
- White matt surface (80% remission)	0.3 to 80 m	0.3 to 100 m
- Reflective tape Oralite ® 5200 white	15 m to 150 m	25 m to 150 m
Measuring accuracy (1)	±1 mm typical ±3 mm (+15 °C up to +30 °C / +59 °F up to +86°F) ±5 mm (-10 °C up to +50 °C / +14 °F up to +122 °F)	
Mode vs Measuring time	Auto	Automatic, depending on surface. Typical: 0.25 – 0.5 sec
	Tracking	20 - 125 ms
	Detection	300 - 600 ms
	Fixed sampling	300 - 600 ms
	Average	300 - 600 ms (moving averaging x2 or x4)
Target speed	Max 4 m/s (Tracking mode)	

(1) At 1 sigma (statistic spread 68%)

Accuracy can be deteriorated by an intense ambient light, a reflecting or an absorbing surface, air turbulences.



Laser Class 2
Laser Class 3R

Model	FT18•1•••	FT18•2••C	FT18•3••C	FT18•4••C	FT18•5••C
Communication protocol	-	Profibus-DP	Profinet	Modbus-TCP	EtherNet/IP
Communication link	-	2 status LED			
Analogue output	4-20 mA (500 Ω max.) ±0.1% temperature drift 50ppm/°C				
Digital output (x3)	3x PNP "High side" 50 mA: - Product presence (PP): 24 V in presence of product - Alarm (AL): 24 V in case of internal failure / temperature - Control (CT): 24 V in case of too low margin (only FT18•1)				
Display	5 digits LED display, 2 status LED				
Setting	2 rotary switches to: * choose between preconfigured fields * select & adjust measuring range, address & mode (Tracking, Detection, Averaging, Fixed Sampling) Setting can also be done via communication link (FT18•4)				
Operating voltage / Power consumption	VDC: 10 to 30 VDC / 10 W max. VAC: 115 V (-15%) to 230 V (+10%) – 50/60 Hz / 5 VA (only available on FT18•1••C)				
Cable	Power supply and analogue outputs cable: connector fitted with silicone cable with protective steel braid. Standard length of 2 m (other length: 3, 5 or 8 m) Communication cables: not included, see Accessories				
Weight	2.6 kg (FT18••- LB) - 3.0 kg (FT18••- JC)				
Protection rating	IP 66 (cast aluminium case)				
Air Purging	Protection of the optic with clean air: 50 to 200 g/cm ² , 4 to 16 l/min				
Operating temperature (2)	-10 °C to 50 °C (14 °F to 122 °F) without cooling. Up to 120 °C (250 °F) with water cooling: industrial quality water at about 25 °C, pressure 1-2 bar and flow 1-2 l/min.				

(2) To increase the lifetime of laser module, it is recommended to cool the sensor with water as soon as operating temperature is > 45°C (113°F) and to switch off the sensor when it's not in operation for many hours.



Connection

Models with 4-20mA output:

Terminal Block (FT18•1•B)

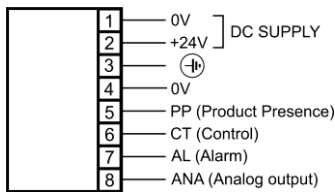

Connector (FT18•1•C)

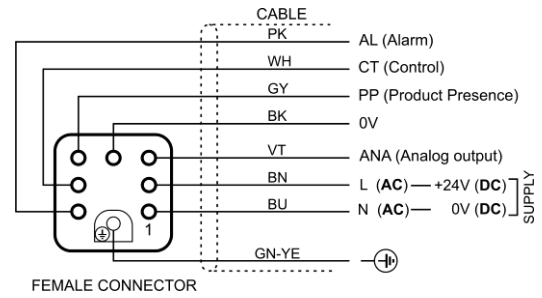

Models with 4-20mA output & communication protocol:

POWER SUPPLY & I/O
5 PIN A-CODED
MALE CONNECTOR

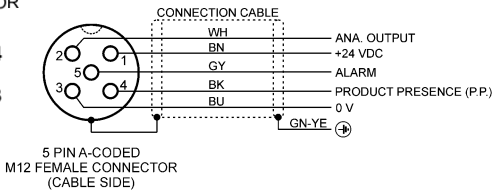
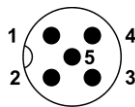

PROFIBUS IN
5 PIN B-CODED
MALE CONNECTOR

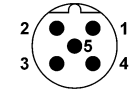

- 1 : NC *
- 2 : PB_A_IN
- 3 : NC *
- 4 : PB_B_IN
- 5 : ⊕

PROFIBUS OUT
5 PIN B-CODED
FEMALE CONNECTOR

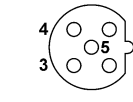

- 1 : 5 V BUS
- 2 : PB_A_OUT
- 3 : 0 V BUS
- 4 : PB_B_OUT
- 5 : ⊕

Ethernet Protocols:
PROFINET
Modbus-TCP
EtherNet/IP
4 PIN D-CODED
FEMALE CONNECTOR

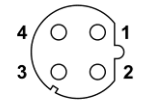

- 1 : TD+
- 2 : RD+
- 3 : TD-
- 4 : RD-

* NOT CONNECTED

Dimensions

Models with 4-20mA output:

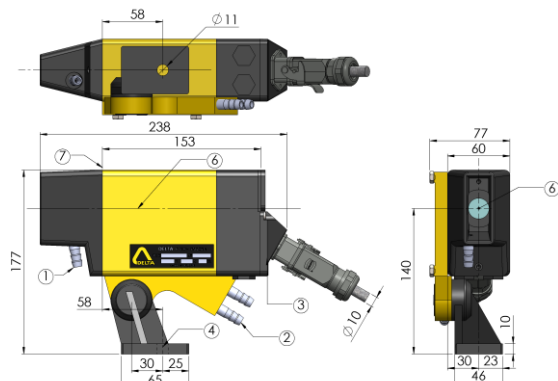
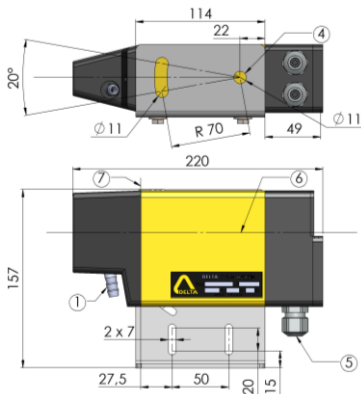

- ① Air supply \varnothing 10
- ② Water supplies \varnothing 10
- ③ Connector clearance 120 mm
- ④ Mounting with screw \varnothing 10
- ⑤ 2 cable glands (cable \varnothing from 7 to 10.5 mm)
- ⑥ Optical axis
- ⑦ Measurement Ref.

Models with 4-20mA output & communication protocol:

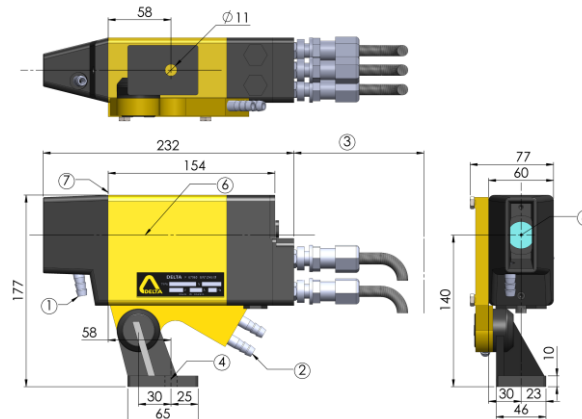
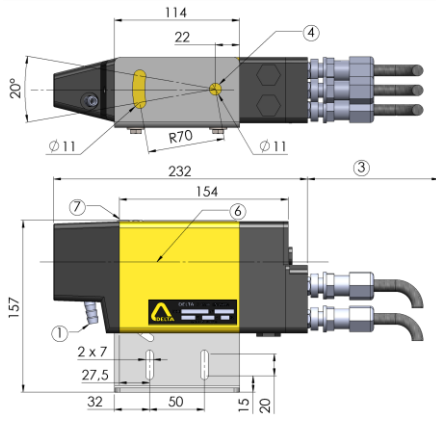



- ③ Connector clearance 140 mm

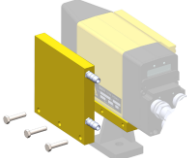

Accessories

For all models

Description		Reference
<p>Heat shield to protect from direct radiation. Only compatible with Mounting stand & cooling jacket (FT18••-J•)</p>		7093146
<p>Additional cooling plate Only compatible with Mounting stand & cooling jacket (FT18••-J•)</p>		7094605
<p>Reflective tape Oralite 5200 white, 1 m x 1 m, for distances between 15 and 150 m.</p>		2636434

For models with Modbus-TCP (FT18•4):

Remote Display unit
(connection to 1 or 2 sensors)

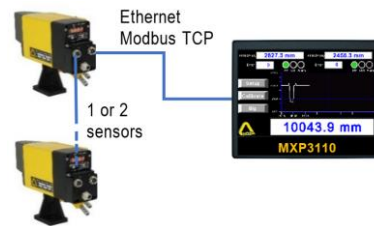

For display on the operator pulpit for cut to length application for example, or in case the access to the sensor is difficult or dangerous.
Display of sensor measurement, status and error code.



Remote Display unit with 1 dimension static calculation
(connection to 2 sensors)

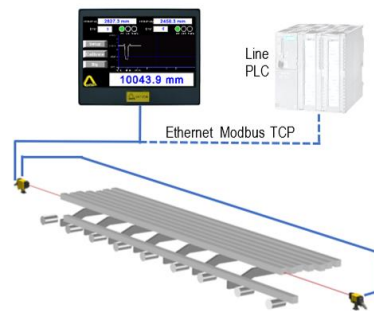

For calculation and display of 1 dimension: width, length, thickness.
Calibration procedure (distance between sensors and correction coefficients).
Display of sensors measurements, status and error code.
Dimension value and calibration parameters stored in each sensor for access through Modbus TCP.



Description		Reference
<p>Standalone display unit To be mounted in an existing panel</p>		MXP3110
<p>Complete junction box including: - 1 Ethernet Switch, - 2 connectors for power supply & I/O of sensors, - 2 Ethernet M12 connectors, - Terminal blocks, - 115/230 VAC to 24 VDC power supply</p>		CR1800FT



For models Dilas FT18•2 (Profibus-DP)

Description		Length	Reference	
A side connector of Profibus cable: Male, M12, 5 pin B-coded, Straight	B side connector of Profibus cable: Female, M12, 5 pin B-coded, Straight		2 m	7540296
			3 m	7540297
			5 m	7540290
			10 m	7540298
			15 m	7540457
			20 m	7540299
Termination resistor for Profibus (male connector M12, B-coded)			2536756	

For models with Ethernet protocols (Profinet, Modbus-TCP, EtherNet/IP)

Description		Length	Reference	
A side connector of Ethernet cable: Male, M12, 4 pin D-coded, Straight	B side connector of Ethernet cable: Male, M12, 4 pin D-coded, Straight		2 m	7540273
			3 m	7540276
			5 m	7540277
			10 m	7540278
			15 m	7540291
			20 m	7540279

Reference for order

Dilas FT 18 • • • - • • • • • L = •

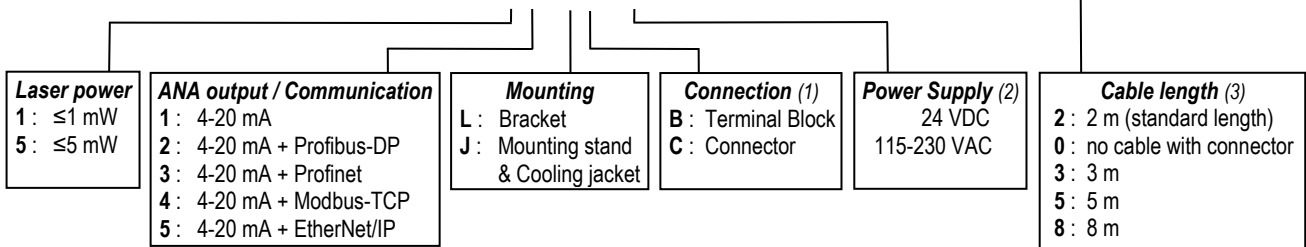

- (1) Terminal block only available for FT18•1•B
- (2) Power supply 115-230 VAC only available for FT18•1•C
- (3) Cable not available for FT18•1•B

Example: **FT1812-JC 24VDC L=2**: Dilas FT1800 sensor with 1mW laser, 4-20mA analogue output, Profibus-DP communication, mounting stand & cooling plate, 2 m cable with connector for power and analogue output (communication cables not included).

DELTA

Tel : +33 388 78 21 01 - Fax : +33 388 76 02 29
info@deltasensor.eu - www.deltasensor.eu

DELTA Sensor (China)

Tel: +86 519 8188 2500 - Fax: +86 519-8188 2400 - info@deltasensor.com.cn

DELTA Vertriebsgesellschaft mbH (Germany)

Tel: +49 700 3358 2736 - Fax: +49 700 3358 2835 - info.de@deltasensor.eu

DELTA Sensor (India)

Tel: +91 11 4054 8170 - Fax: +91 11 4054 8172 - info@deltasensor.co.in

DELTA USA, Inc. (North America)

Tel: +1 (412) 429 3574 - Fax: +1 (412) 429 3348 - info@delta-usa.com

DELTA Sensor (Russia)

Tel: + 7 916 682 6027 - info.ru@deltasensor.eu

Subject to change without prior notice.
Non contractual pictures.